

SPECIFICATIONS

Maximum Input	3,000 BHP (2,237 kW)
Maximum RPM	250
No. of Plungers	3
Stroke Length	11" (279 mm)
Piston Load	350,000 lbs. (1,556,878 N)
Pump Weight	18,550 lbs. (8,368 kg)
Gear Ratio	7.8:1

Pumping Perfected.™

Plunger Diameter		Displacement per Revolution		Displacement at Pump RPM - Intermittent Service															
				50				100				200				250			
in.	mm.	Gal.	m ³	GPM	m ³ /hr	PSI	bar	GPM	m ³ /hr	PSI	bar	GPM	m ³ /hr	PSI	bar	GPM	m ³ /hr	PSI	bar
4.5	114	2.271	0.0086	114*	26*	20000*	1379*	227*	52*	20000*	1379*	454	103	10200	703	568	129	8150	562
5	127	2.804	0.0106	140	32	17850	1231	280	64	16500	1138	561	127	8250	569	701	159	6600	455
5.5	140	3.392	0.0128	170	39	14750	1017	339	77	13650	941	678	154	6800	469	848	193	5450	376
5.75	146	3.708	0.0140	185	42	13500	931	371	84	12500	862	742	169	6250	431	927	211	5000	345
6	152	4.037	0.0153	202	46	12400	855	404	92	11450	789	807	183	5750	396	1009	229	4600	317
6.5	165	4.738	0.0179	237	54	10550	727	474	108	9750	672	948	215	4900	338	1185	269	3900	269
7	178	5.495	0.0208	275	62	9100	627	550	125	8400	579	1099	250	4200	290	1374	312	3350	231

Ratings are based on 90% mechanical efficiency and 100% volumetric efficiency.
*Contact Gardner Denver Engineering for application review and approval.

GD-3000 Well Service Pump

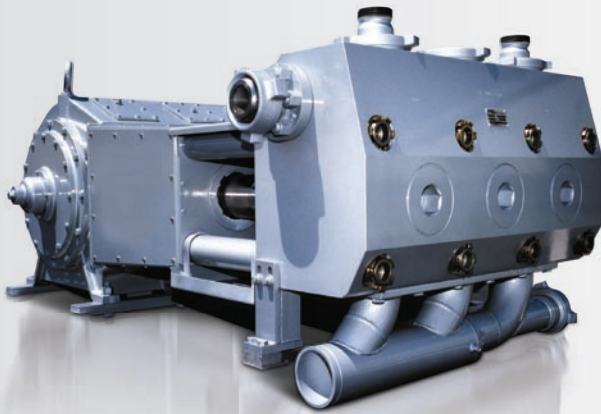

STANDARD FEATURES

- Modular power end design featuring high power density planetary gearbox with offset
- Left or right side gearbox mounting position
- Forged, heat treated alloy steel crankshaft
- Cross drilled crankshaft and connecting rod for pressurized oil flow to critical components
- Coated crosshead surfaces for wear resistance
- Hardened surface on connecting rod thrust knuckle for severe duty applications
- Forged SAE 4330 autofrettaged fluid end for extended field service
- Through stud fluid end design for maintenance and removal ease
- Replaceable stuffing boxes allowing convenient plunger size conversion
- WECO style discharge flanges
- 6 in. high flow, zoomie style suction manifold

OPTIONAL FEATURES

- DNV, ABS, PED or other third party certifications
- Patented Self Tightening Valve Cover Retainer Lock System
- Splined flange for gear reducer
- Dual discharge flanges
- Various plunger packing styles
- Additional center gauge connection
- Hydraulic torque wrench for fluid end removal

SPECIFICATIONS

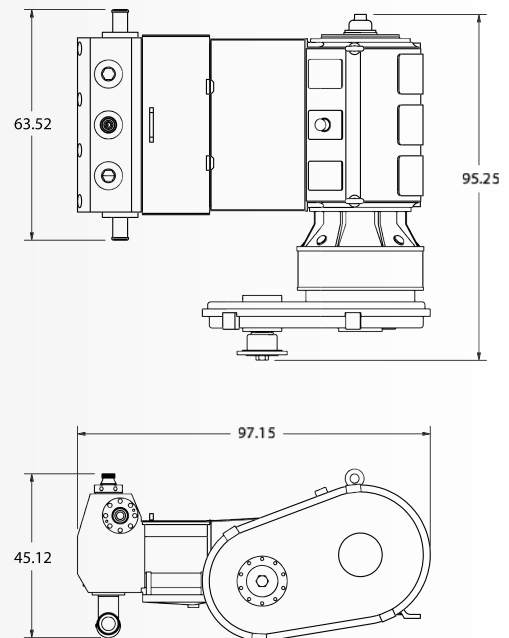

Drilling & Production Pumps
Gardner Denver Pump Division
1800 Gardner Expressway
Quincy, IL 62305
Phone: 217-222-5400
Fax: 217-223-1581

Drilling & Production Aftermarket
Gardner Denver Pump Division
2200 South Prospect
Oklahoma City, OK 73129
Phone: 405-677-5736
Fax: 405-677-5807

Well Service Pumps
Gardner Denver Pump Division
4747 South 83rd East Avenue
Tulsa, OK 74145
Phone: 918-664-1151
Fax: 918-447-6487

Fort Worth Service Center
Gardner Denver Pump Division
7533 Kathy Lane
Fort Worth, TX 76126
Phone: 817-249-6400
Fax: 817-249-6383

Odessa Service Center
Gardner Denver Pump Division
2121 West 44th Street
Odessa, TX 79764
Phone: 432-366-5433
Fax: 432-363-9940